

The Premium Pump for Higher Pressure

LKHI Centrifugal Pump for 16 bar Inlet Pressure

Application

The LKHI pump is a highly efficient and economical centrifugal pump, specially designed for inlet pressures up to 16 bar. LKHI meets the requirements of sanitary and gentle product treatment and chemical resistance, and is available in nine sizes, LKHI-10, -15, -20, -25, -35, -40, -45, -50, -60.

Standard Design

The LKHI pump consists of a special motor, stub shaft, compression coupling, adaptor, back plate, impeller, pump casing and shaft seal. The LKHI pump is designed for CIP-cleaning with emphasis on large internal roundings and easily cleanable seals. LKHI is a sanitary pump with a stainless steel shroud for protection of the motor. The complete unit is supported on four adjustable stainless steel legs.

Shaft seals

LKHI can be fitted with two types of mechanical seals:

- Single internal seal.
- Flushed seal.

Both seal types have stationary seal rings of silicon carbide and rotating seal rings of carbon or silicon carbide:

1. Silicon carbide/carbon for inlet pressure up to 10 bar.
 2. Silicon carbide/silicon carbide for inlet pressure higher than 10 bar.
- The secondary seal of the flushed seal is a long lasting lip seal.

Materials

Product wetted steel parts: Acid-resistant steel, 1.4404 (316L).

Other steel parts: Stainless steel, 1.4301 (304).

Product wetted seals: EPDM.

Other O-rings: EPDM.

Finish: Semi-bright.

Technical data

Max. inlet pressure: 1600 kPa (16 bar).

Temperature range: -10°C to +140°C (EPDM).

Water pressure: Normally atmospheric.
 (max. 1 bar).

Water consumption: 0.25 - 0.5 l/min.
 (Flushed seal)

Noise level (at 1 m): 60 - 80 dB (A).



LKHI.

Motor

Foot-flanged motor according to the IEC metric standard, 2 poles = 3000/3600 rpm. at 50/60 Hz, IP 55 (with drain hole with labyrinth plug), insulation class F.

Motor types:

- Standard motor with a fixed ball bearing on drive side.
- Special motor with a fixed angular-contact ball bearing on drive side.

Motor sizes (kW)	Inlet pressure (bar)	
	0-10	>10
1.5 - 30 (50 Hz)	Standard motor	Special motor
1.75 - 35 (60 Hz)		

Note! The special motor must be ordered for inlet pressure >10 bar.

Voltage and frequency

3 ~, 50 Hz, 220-240V Δ/380-420VY ≤ 4 kW
 3 ~, 60 Hz, 250-280V Δ/440-480VY ≤ 4.6 kW

3 ~, 50 Hz, 380-420V Δ/660-690VY ≥ 5.5 kW
 3 ~, 60 Hz, 440-480V Δ ≥ 6.3 kW

Motor sizes

50 Hz: 1.5, 2.2, 3.0, 4.0, 5.5, 7.5, 11.0, 15.0, 18.5, 22.0, 30.0 kW.
60 Hz: 1.75, 2.5, 4.6, 6.3, 8.6, 12.5, 17.0, 21.0, 25.0, 35.0 kW

Dimensions (mm)

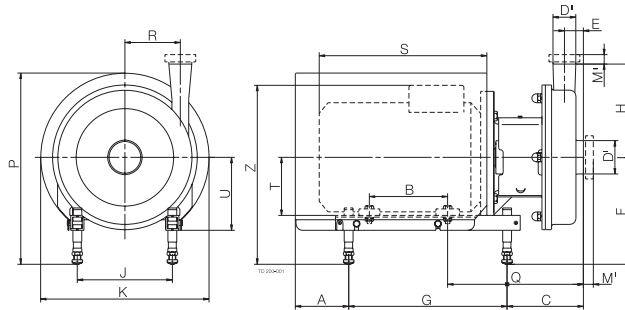

LKHI-10

	Motor kW			
	1.5	2.2	3	4
A	139	139	78	81
B	100	125	140	140
C	132	132	140	147
E	23	23	23	23
F min.	189	189	185	184
F max.	275	275	295	297
G	272	272	320	320
H	142	142	142	142
J	140	140	160	190
K	288	288	323	359
P min.	346	346	357	383
P max.	432	432	467	496
Q	215	215	235	242
R	87	87	87	87
*S	245	270	299	301
T	90	90	100	112
U	125	125	145	147
Z min.	316	316	321	330
Z max.	402	402	431	443
Weight (kg)	36	39	47	57

LKHI-15

	Motor kW		
	3	4	5.5
A	78	81	81
B	140	140	178
C	176	183	181
E	43	43	43
F min.	185	184	184
F max.	295	297	317
G	320	320	400
H	166	166	166
J	160	190	216
K	323	359	383
P min.	357	383	380
P max.	467	492	513
Q	271	278	316
R	66	66	66
*S	299	301	402
T	100	112	132
U	145	147	167
Z min.	321	330	348
Z max.	431	443	481
Weight (kg)	51	61	79

LKHI-20

	Motor kW			
	2.2	3	4	5.5 / 7.5
A	139	78	81	81
B	125	140	140	178
C	145	152	159	157
E	27	27	27	27
F min.	189	185	184	184
F max.	275	295	297	317
G	272	320	320	400
H	180	180	180	180
J	140	160	190	216
K	288	323	359	383
P min.	346	357	383	380
P max.	432	467	496	513
Q	227	247	254	292
R	88	88	88	88
*S	270	299	301	402
T	90	100	112	132
U	125	145	147	167
Z min.	316	321	330	348
Z max.	402	431	443	481
Weight (kg)	41	49	59	77

LKHI-25

	Motor kW	
	5.5/7.5	11/15
A	81	105
B	178	210
C	168	197
E	32	32
F min.	184	228
F max.	317	345
G	400	483
H	193	193
J	216	254
K	383	485
P min.	380	486
P max.	513	607
Q	303	350
R	106	106
*S	402	493
T	132	160
U	167	195
Z min.	348	438
Z max.	481	554
Weight (kg)	84	128/137

Note! *S for pumps with ABB motors.

900003/6

Dimensions (mm)

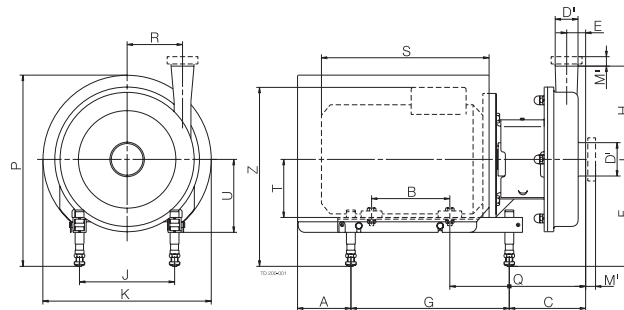

LKHI-35

	Motor kW		
	4	5.5/7.5	11/15
A	81	81	105
B	140	178	210
C	155	153	182
E	23	23	23
F min.	184	184	228
F max.	297	317	345
G	320	400	483
H	193	193	193
J	190	216	254
K	359	383	485
P min.	383	380	490
P max.	496	513	607
Q	250	288	335
R	119	119	119
*S	301	402	493
T	112	132	160
U	147	167	195
Z min.	330	348	438
Z max.	443	481	554
Weight (kg)	66	84	128/137

LKHI-40

	Motor kW		
	7.5	11/15/18.5	22
A	81	105	156
B	178	210	241
C	163	192	206
E	28	28	28
F min.	184	228	260
F max.	317	345	365
G	400	483	508
H	212	212	212
J	216	254	279
K	383	485	533
P min.	380	490	546
P max.	513	607	671
Q	298	345	358
R	126	126	126
*S	402	493	570
T	132	160	180
U	167	195	215
Z min.	348	438	484
Z max.	481	554	589
Weight (kg)	87	131/140/150	177

LKHI-45

	Motor kW		
	4	5.5/7.5	11/15
A	81	81	105
B	140	178	210
C	184	182	211
E	41	41	41
F min.	184	184	228
F max.	297	317	345
G	320	400	483
H	193	193	193
J	190	216	254
K	359	383	485
P min.	383	380	490
P max.	496	513	607
Q	279	317	364
R	97	97	97
*S	301	402	493
T	112	132	160
U	147	167	195
Z min.	330	347	438
Z max.	443	480	555
Weight (kg)	68	86	130/139

LKHI-50

	Motor kW		
	5.5/7.5	11/15/18.5	22
A	81	105	156
B	178	210	241
C	176	205	218
E	35	35	35
F min.	184	228	260
F max.	317	345	365
G	400	483	508
H	205	205	205
J	216	254	279
K	383	485	534
P min.	380	490	546
P max.	513	607	671
Q	311	358	371
R	118	118	118
*S	402	493	570
T	132	160	180
U	167	195	215
Z min.	348	438	484
Z max.	481	554	589
Weight (kg)	86	133/142/152	177

Note! *S for pumps with ABB motors.

900003/6

Dimensions (mm)

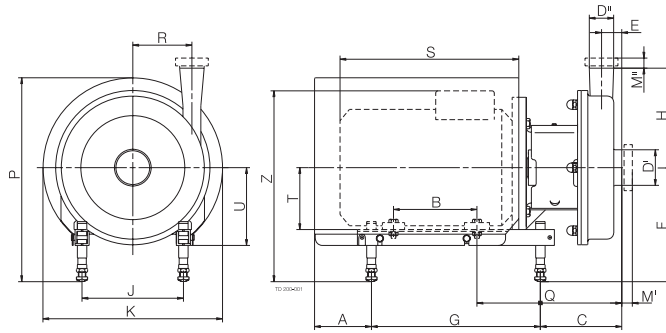

LKHI-60

	Motor			
	kW			
	5.5/7.5	11/15/18.5	22	30
A	81	105	156	246
B	178	210	241	305
C DN150	255	284	297	309
C 4"	205	234	247	259
C clamp 6"	245	274	287	299
E DN150	112	112	112	112
E 4"	62	62	62	62
E clamp 6"	102	102	102	102
F min.	184	228	260	260
F max.	317	345	365	385
G	400	483	508	534
H	262	262	262	262
J	216	254	279	318
K	383	485	534	673
P min.	380	490	546	661
P max.	513	607	671	786
Q DN150	390	437	450	462
Q 4"	340	387	400	412
Q clamp 6"	380	427	440	452
R	102	102	102	102
*S	402	493	570	700
T	132	160	180	200
U	167	195	215	220
Z min.	348	437	484	585
Z max.	481	554	589	710
Weight (kg)	97	141/150/160	185	330

Note! *S for pumps with ABB motors.

Volumetric flow

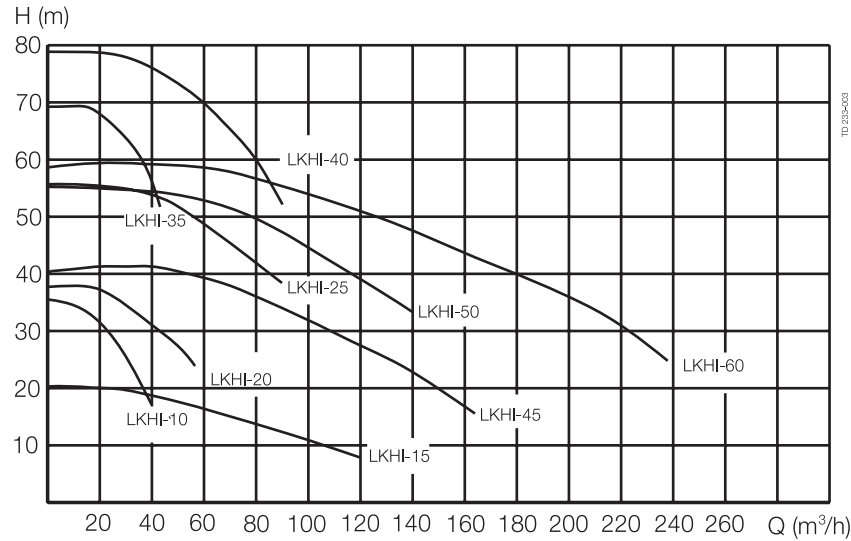

Connections (mm)

LKHI-10, -20, -35

D ^I 63.5	ISO	ISO	DIN	SMS	BS
D ^{II} 51	Clamp	Male	Male	Male	Male
M ^I	21	21	25	24	22
M ^{II}	21	21	22	20	22

LKHI-15, -45, -50

D ^I 101.6	ISO	ISO	DIN	SMS	BS
D ^{II} 76.1	Clamp	Male	Male	Male	Male
M ^I	21	21	30	35	27
M ^{II}	21	21	30	24	22

LKHI-25

D ^I 76.1	ISO	ISO	DIN	SMS	BS
D ^{II} 63.5	Clamp	Male	Male	Male	Male
M ^I	21	21	30	24	22
M ^{II}	21	21	25	24	22

LKHI-60

D ^I 101.6	ISO	ISO	DIN	SMS	BS
D ^{II} 101.6	Clamp	Male	Male	Male	Male
M ^I	21	21	30	35	27
M ^{II}	21	21	30	35	27

LKHI-40

D ^I 76.1	ISO	ISO	DIN	SMS	BS
D ^{II} 63.5	Clamp	Male	Male	Male	Male
M ^I	21	21	30	24	22
M ^{II}	12	21	27	24	17

D ^I DN150	DIN	D ^I 6"	ISO
D ^{II} DN100	Male	D ^{II} 4"	Clamp
M ^I	50	M ^I	38
M ^{II}	30	M ^{II}	16

Options

- A. Impeller with reduced diameter.
- B. Impeller screw.
- C. Motor for other voltage and/or frequency.
- D. 1500 rpm. motor.
- E. Motor with increased safety/flame proof motor.
- F. Flushed shaft seal.
- G. Seals in Nitrile (NBR) or Fluorinated rubber (FPM).
- H. Surface roughness, product wetted parts: $R_a \leq 0.8 \mu\text{m}$.
- I. Product wetted seals of Nitrile (NBR) or Fluorinated rubber (FPM).
- J. Seal faces in SIC/SIC (Silicon Carbide).

Ordering

Please state the following when ordering:

- Pump size.
- Pressure.
- Connections
- Impeller diameter.
- Motor size.
- Single or flushed shaft seal.
- Optional extras.

Note!

- The curves for LKHI are the same as those for LKH.
- For further details, see also Instruction Manual, IM 70820.